

# SPORTJET 460

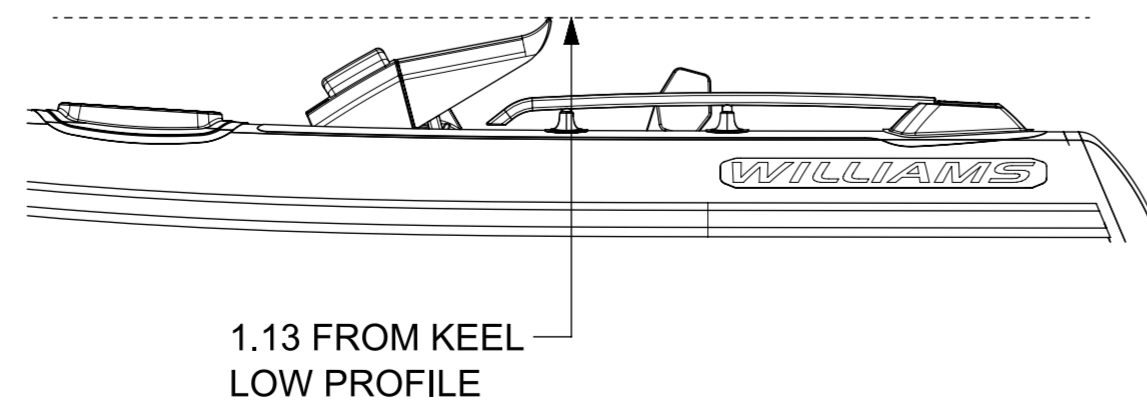
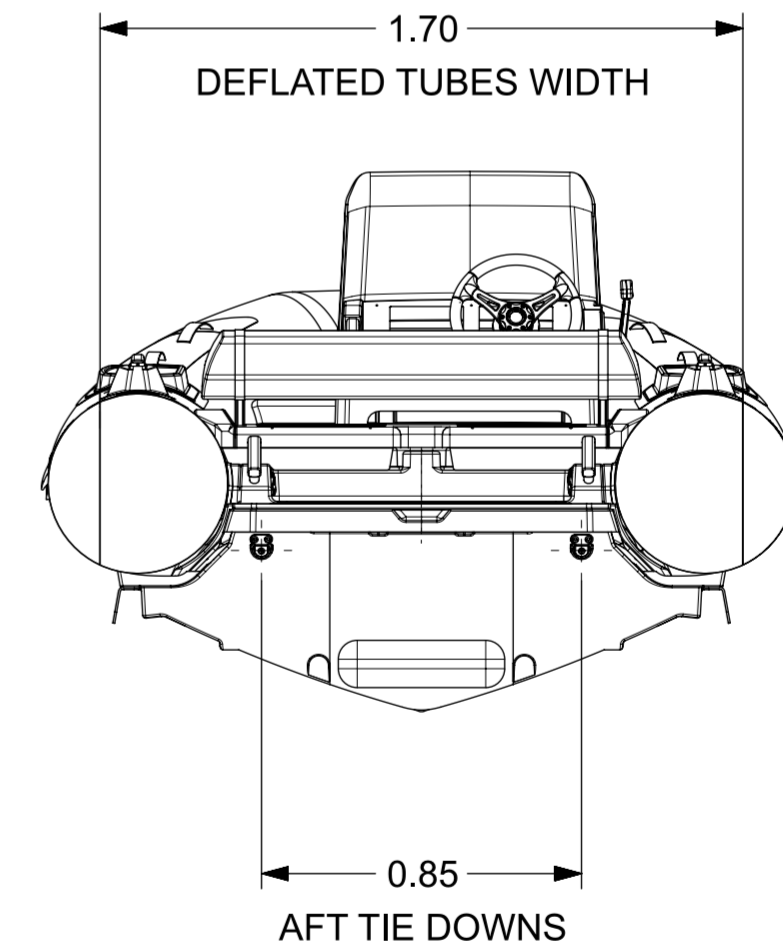
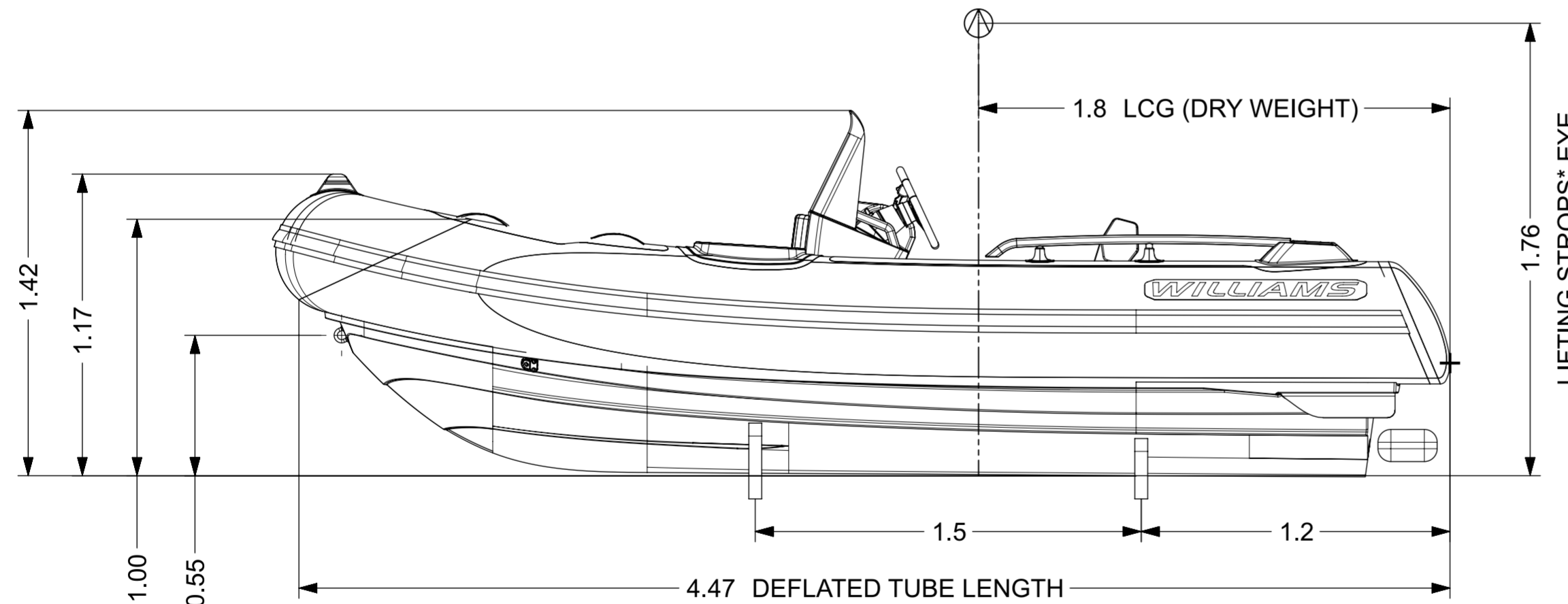
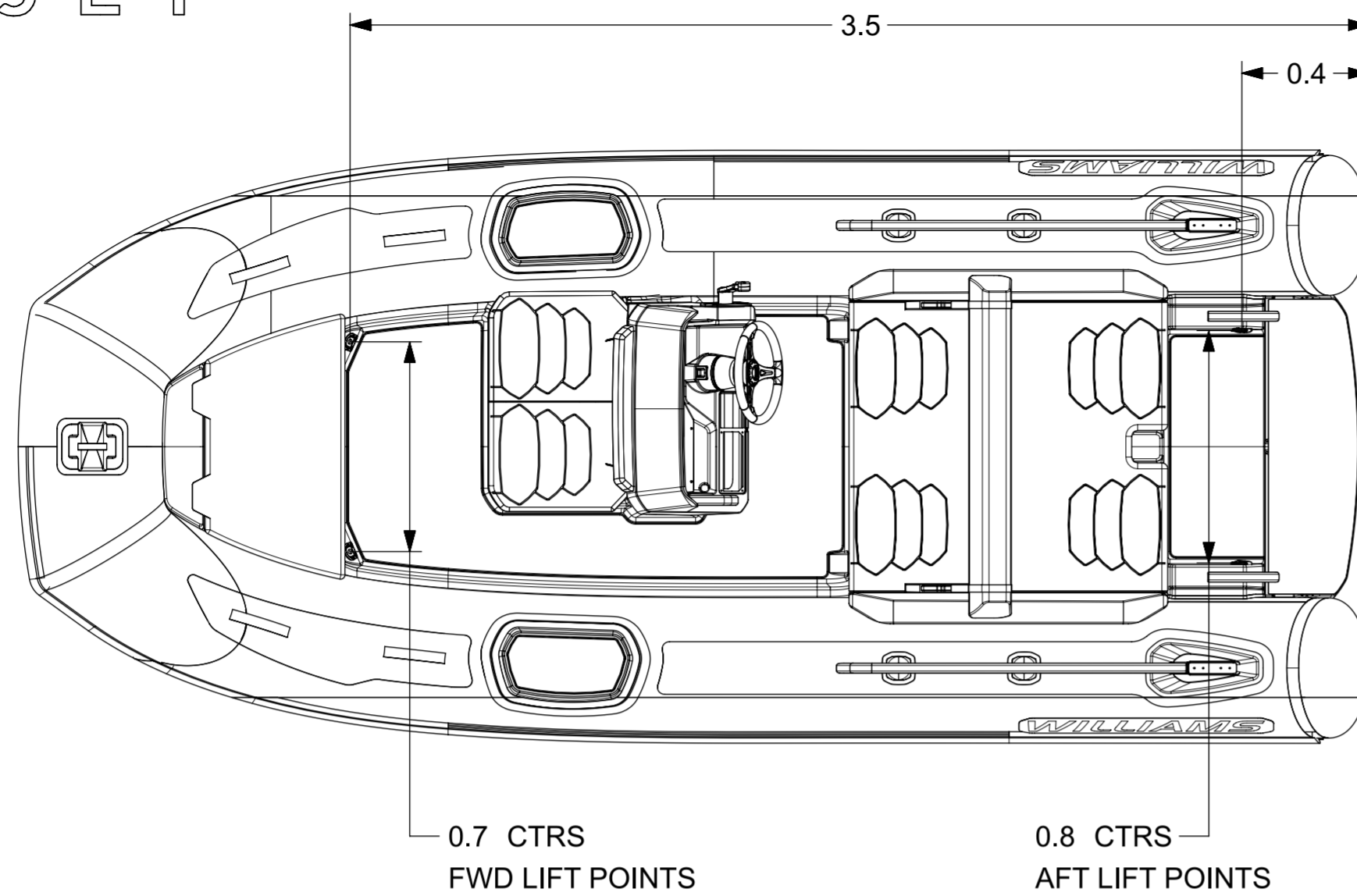

LENGTH	4.59m (±1%)
BEAM	2.01m (±1%)
DRAFT (FULLY LOADED)	0.43m
ENGINE	Rotax 1630 ACE iDF
POWER	170hp ≅ 127kW
DRY WEIGHT	625kg
SEATING CAPACITY	6
FUEL	PETROL
FUEL CAPACITY	100L
MAX. SPEED	48mph ≅ 77kph
No. TUBE COMPARTMENTS	5
CE DESIGN CATEGORY	C

**NOTES:**

1. LENGTH / BEAM TOLERANCE DUE TO VARIATION IN TUBE AIR PRESSURE.
2. AVERAGE DRY WEIGHT STATED;  
ACTUAL WEIGHT DEPENDENT ON OPTIONS FITTED.
3. LOW PROFILE:
  - DEFLATED TUBES (AUTO BOW TUBE INFLATOR REQUIRED\*).
  - QUICK RELEASE STEERING WHEEL.
  - FOLDABLE HELM.
4. REFER TO DWG RD2196 FOR CHOCK PROFILES.
5. ALL DIMENSIONS IN METERS.

\*OPTIONAL ACCESSORY

REV.	DATE	DETAILS	FZ	OBB
1	13/05/2024	FIRST ISSUE		

	GENERAL TOL. 0 ±0.50 0.0 ±0.25 0.00 ±0.10 0 ±0.50
--	---

DRAWN	FZ	DATE	26/04/2024
APPVD	OBB	DATE	13/05/2024
PROJECT:	P96D		
INSPECTION LEVEL:	MATERIAL & FINISH		

<b>WILLIAMS</b>	
<b>SPORTJET 460 (2025MY)</b>	
PART NO.	WPT-000460SJ-P96-2025MY-DATASHEET_dwg1
SCALE	1:20
SHEET	1 OF 1

A2