

MINIJET 280

| | |
|------------------------|------------------|
| LENGTH O.A. | 2.79m (±1%) |
| BEAM O.A. | 1.54m (±1.5%) |
| DRAFT (LOAD DEPENDANT) | 0.24m / 0.35m |
| ENGINE | Rotax ACE 60 ECT |
| POWER | 60hp ≅ 44.13kW |
| DRY WEIGHT | 225kg |
| SEATING CAPACITY | 3 + 1 child |
| FUEL | PETROL |
| FUEL CAPACITY | 28L |
| MAX. SPEED | 40mph ≅ 64kph |
| No. TUBE COMPARTMENTS | 4 |
| CE DESIGN CATEGORY | C |

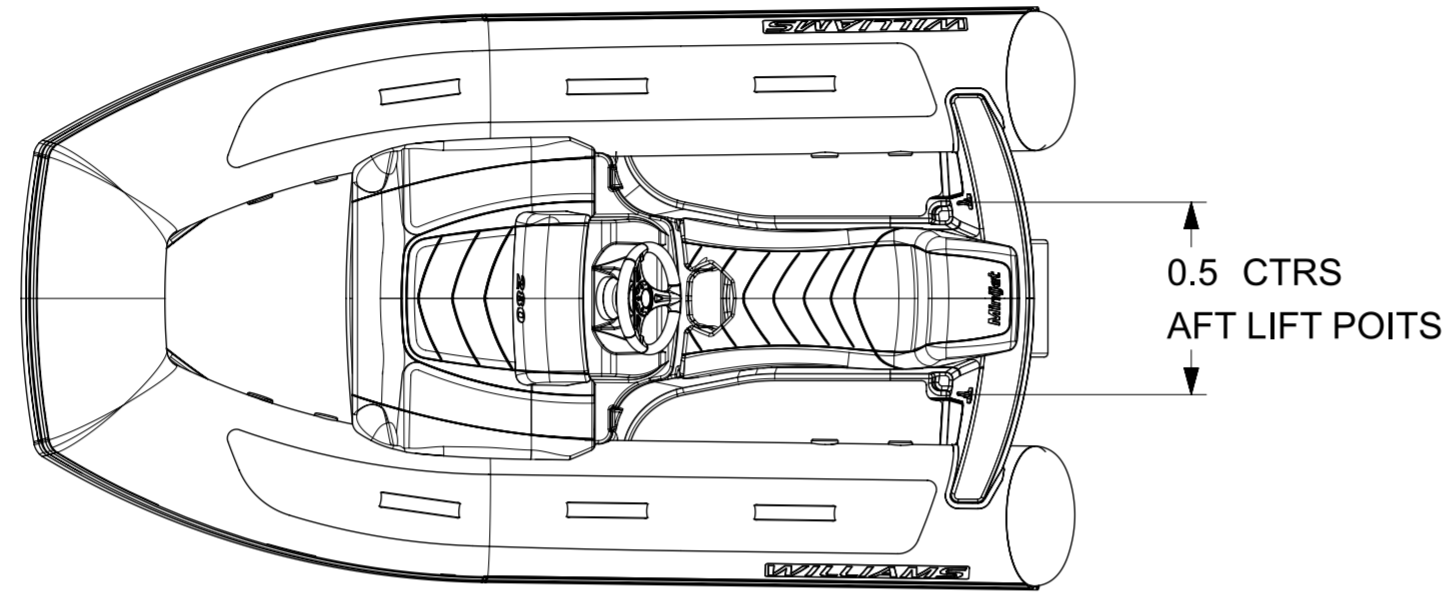

NOTES:

1. LENGTH / BEAM TOLERANCE DUE TO VARIATION IN TUBE PRESSURE.
2. AVERAGE DRY WEIGHT STATED;
ACTUAL WEIGHT DEPENDENT ON OPTIONS FITTED.
3. LOW PROFILE SPEC:
 - REMOVE STEERING WHEEL (QUICK RELEASE TYPE REQUIRED*)
 - DEFLATE TUBES.
4. CHOCK PROFILE'S DRAWING: RD927
CHOCKS* PART NUMBER: 99-0926

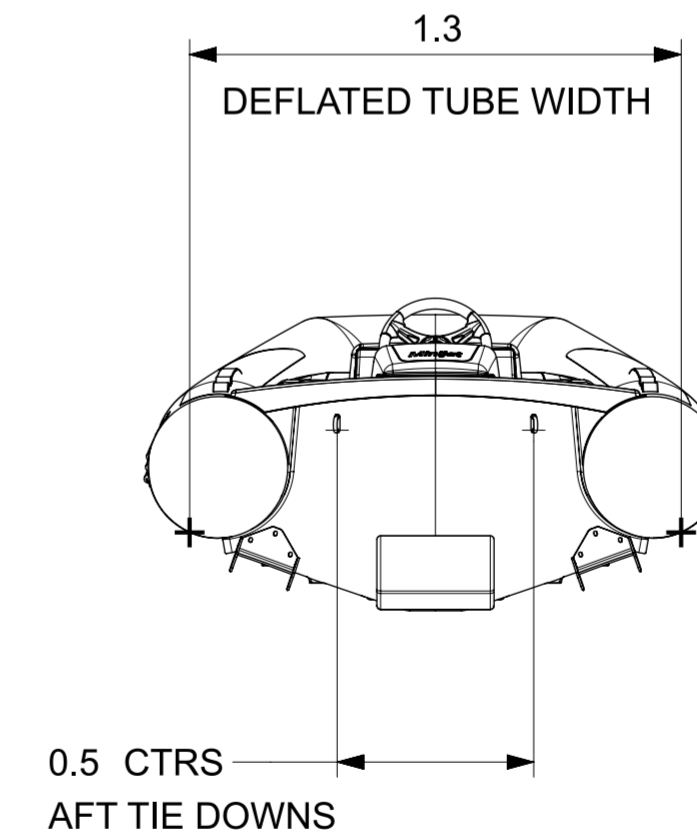
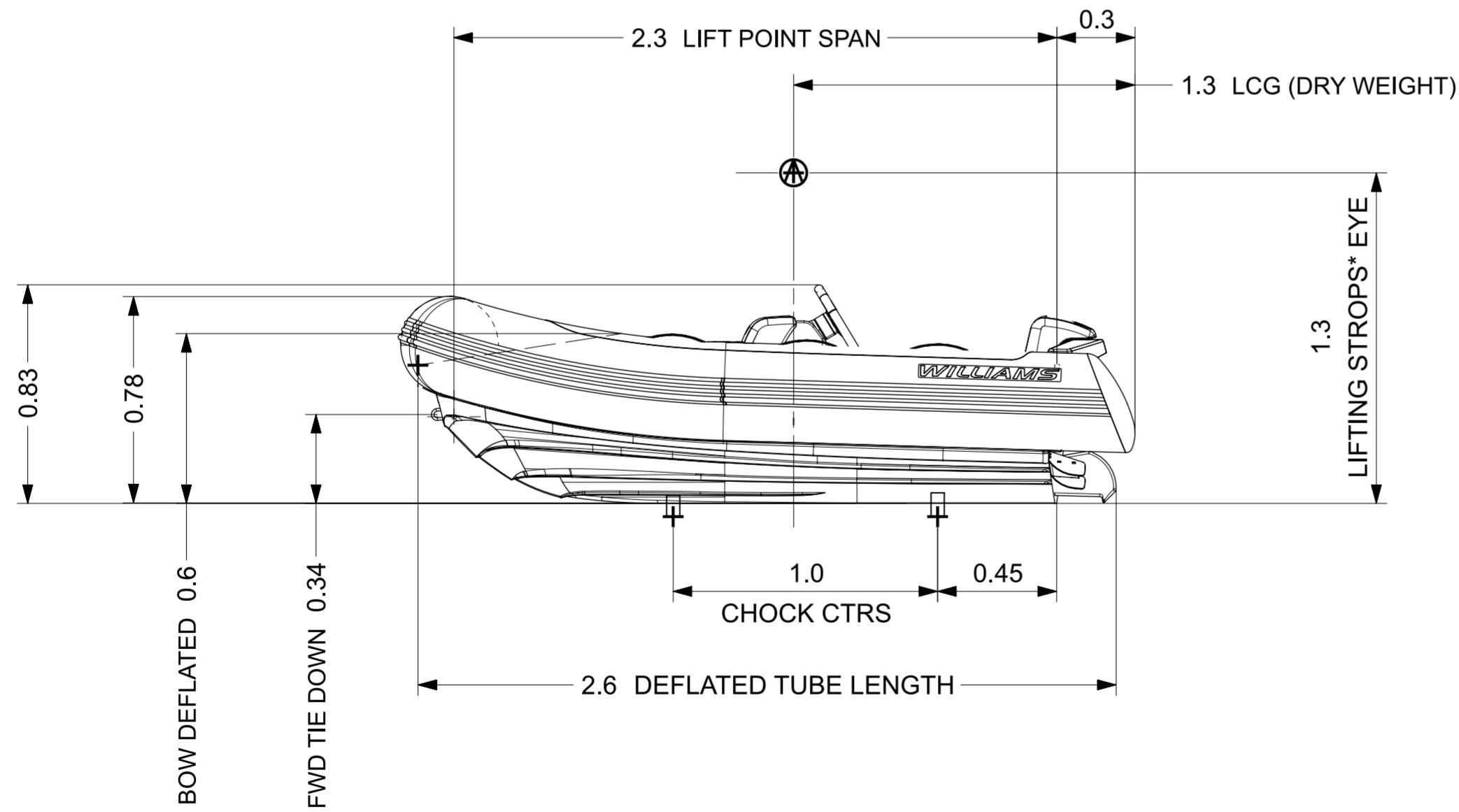

*OPTIONAL ACCESSORY

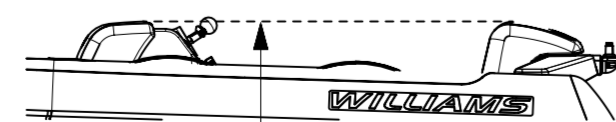

0.71 FROM KEEL
LOW PROFILE*

| REV. | DATE | DETAILS | FZ | OB |
|------|------------|---------------------|-------|-------|
| 1 | 11/10/2023 | PRODUCTION RELEASED | FZ | OB |
| | | | DRAWN | APPVD |

| NAME | DATE |
|----------------------|------------|
| DRAWN FZ | 11/10/2023 |
| APPVD OBB | |
| PROJECT: | - |
| INSPECTION LEVEL: | - |
| MATERIAL & FINISH | - |
| GENERAL SURF FINISH | Ra 1.6UM |
| DO NOT SCALE DRAWING | |

| | | | |
|---|--|-----------------------------|--|
| | | MINIJET 280 (2025MY) | |
| PART NO. WPT-000280MJ-2025MY-DATASHEET -dwg.1 | | A2 | |
| SCALE 1:20 | | SHEET 1 OF 1 | |

NOT FOR PUBLICATION - THIS DRAWING IS THE PROPERTY OF WILLIAMS JET TENDERS LTD. AND IS ISSUED ON CONDITION THAT IT IS NOT COPIED, RE-PRINTED OR DISCLOSED EITHER WHOLLY OR IN PART TO ANY THIRD PARTY NOT AUTHORISED TO RECEIVE IT