

SPORTJET 395

LENGTH O.A.	3.90m (±1%)
BEAM O.A.	1.77m (±1.5%)
DRAFT (FULLY LOADED)	0.33m
ENGINE	Rotax ACE 90 ECT
POWER	90hp ≅ 66.19kW
DRY WEIGHT	388Kg
SEATING CAPACITY	6 + 1 child
FUEL	PETROL
FUEL CAPACITY	50L
MAX. SPEED	46mph ≅ 74kph
No. TUBE COMPARTMENTS	5
CE DESIGN CATEGORY	C

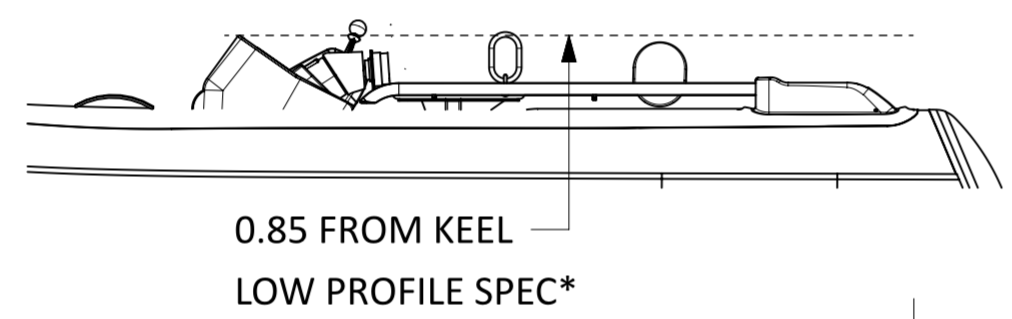
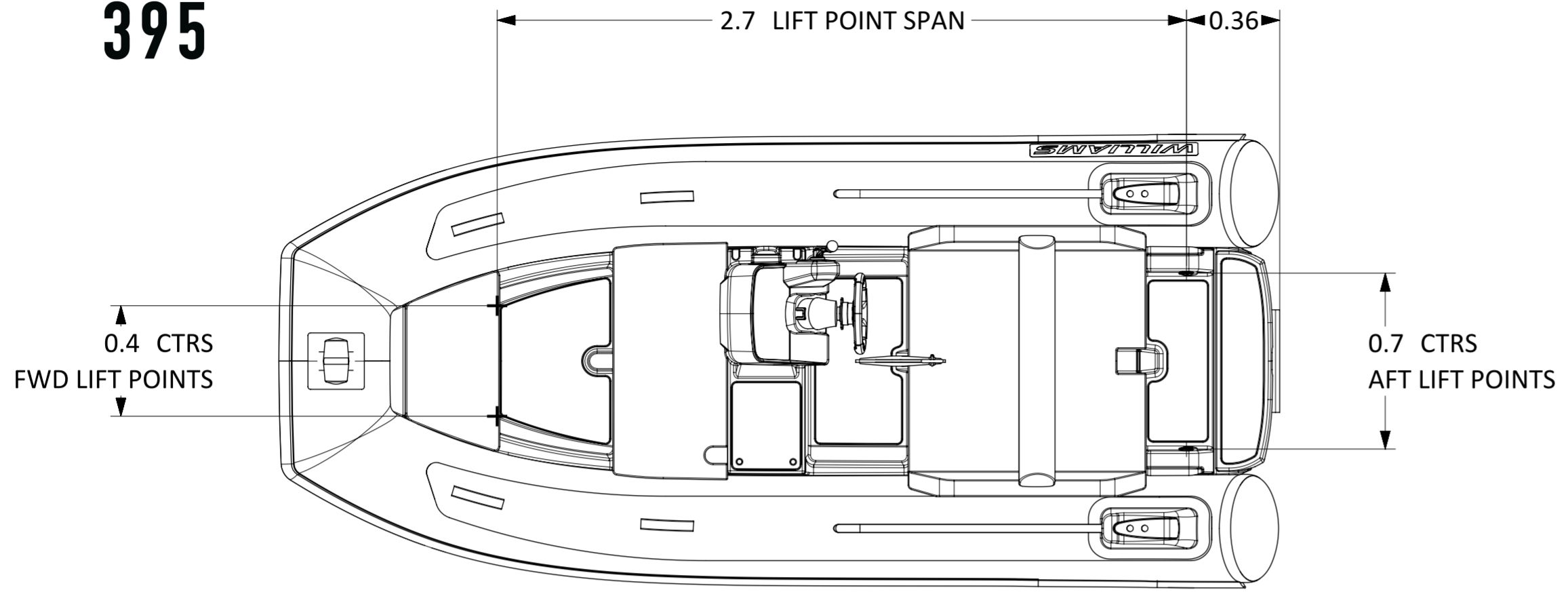

NOTES:

1. LENGTH / BEAM TOLERANCE DUE TO VARIATION IN TUBE PRESSURE.
2. AVERAGE DRY WEIGHT STATED; ACTUAL WEIGHT DEPENDENT ON OPTIONS FITTED.
3. LOW PROFILE SPEC:
-DEFLATE TUBES. (AUTO BOW TUBE INFLATOR OPTION REQUIRED)
-REMOVE STEERING WHEEL (QUICK RELEASE OPTION REQUIRED).
4. STANDARD CHOCK*: 99-0151
CHOCK PROFILES DRAWING: RD1015
5. SINGLE POINT LIFT OPTION*: 99-0987

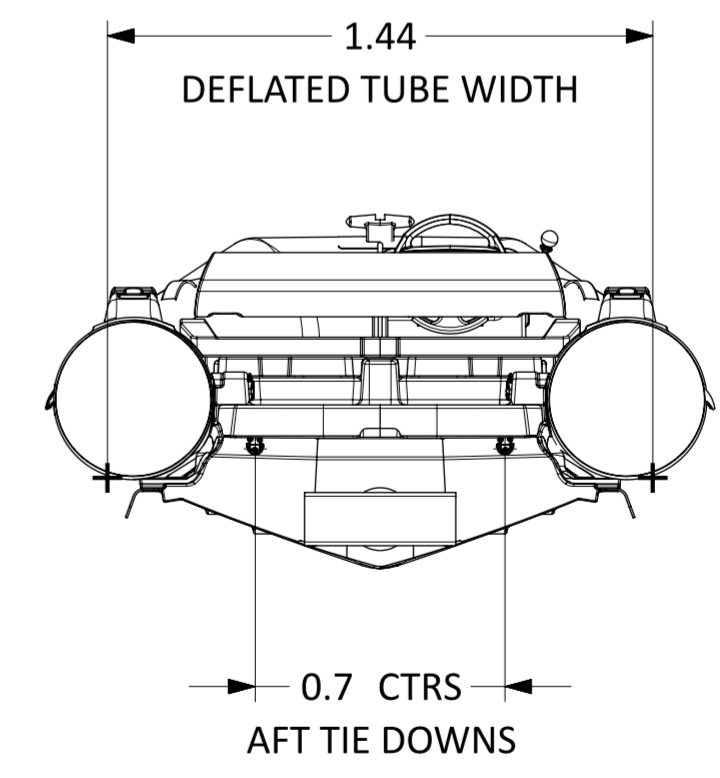
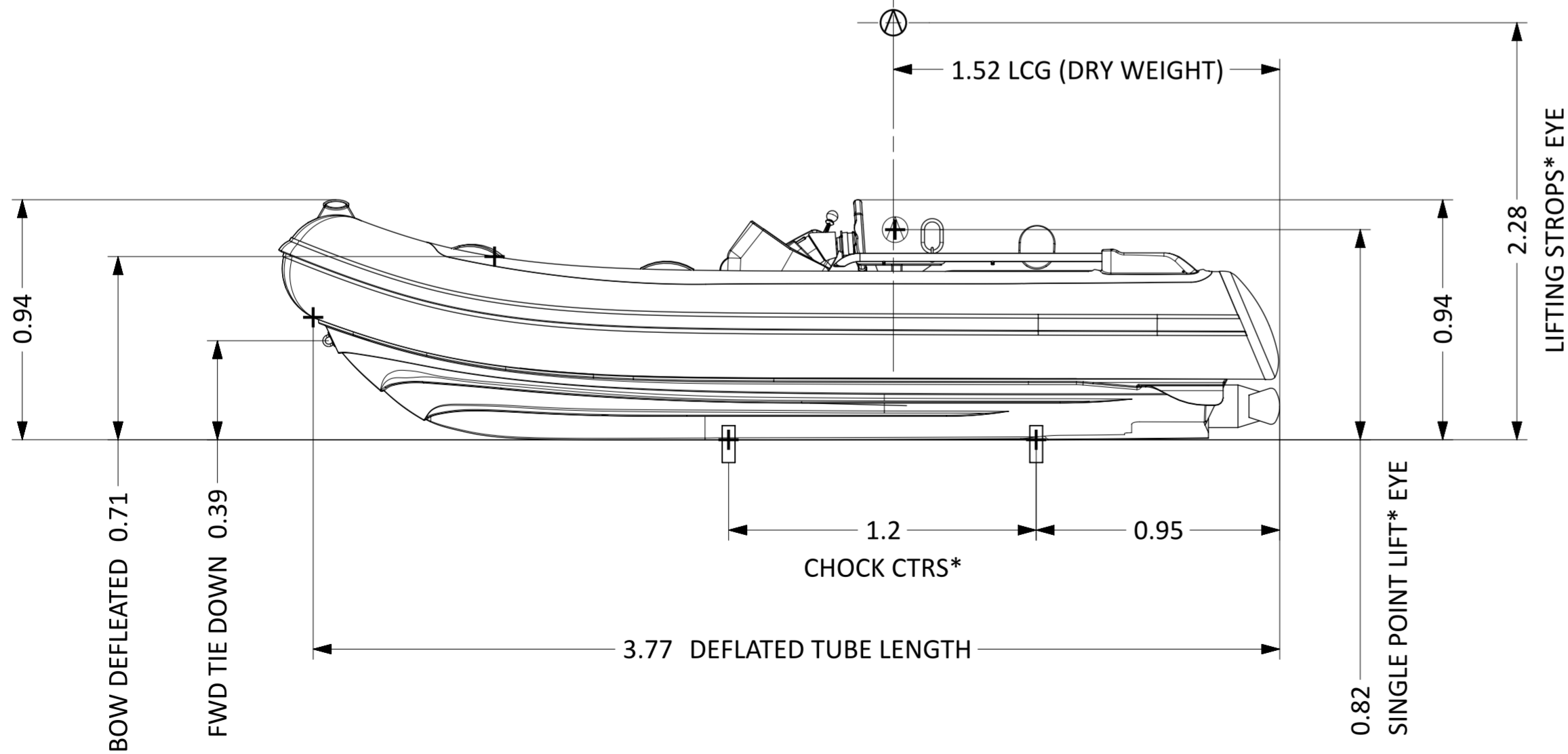

*OPTIONAL ACCESSORY

REV.	DATE	DETAILS	FZ	OBB
1	18/09/2023	PRODUCTION RELEASE	FZ	OBB

NOT FOR PUBLICATION - THIS DRAWING IS THE PROPERTY OF WILLIAMS JET TENDERS LTD. AND IS ISSUED ON CONDITION THAT IT IS NOT COPIED, RE-PRINTED OR DISCLOSED EITHER WHOLLY OR IN PART TO ANY THIRD PARTY NOT AUTHORISED TO RECEIVE IT

NAME	DATE
DRAWN FZ	18/09/2023
APPVD OBB	
PROJECT:	-
INSPECTION LEVEL:	-
MATERIAL & FINISH	-
REMOVE ALL BURRS & BREAK SHARP EDGES	
GENERAL SURFACE FINISH Ra 1.6UM	
DIMENSIONS IN MM UNLESS STATED	
DO NOT SCALE DRAWING	

WILLIAMS

TITLE: **SPORTJET 395 (2025MY)**

PART NO.: **WPT-000395SJ-2025MY-DATASHEET -dwg.1**

SCALE: 1:20

SHEET 1 OF 1